

TECHNICAL DATASHEET



EF REDUCED TEE 90°

04 Update - 04/2024

TECHNICAL DATA

Article No	001 117 2042 0076
d1 (mm)	75
d2 (mm)	63
D (mm)	95
Z (mm)	189
L (mm)	122
le1 (mm)	55
le2 (mm)	67
m (mm)	27,3
Weight (Kg)	0,598
Box Quantity (pcs)	18
Box Dimension (cm)	55x30x43,5

INJECTION MOULDED

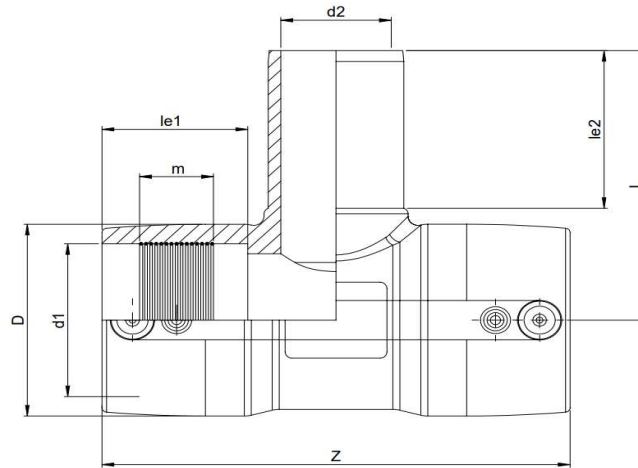

IDENTIFICATION OF PRODUCT

D(mm)	75-63
SDR	11
RAW MATERIAL	PE 100
PRESSURE CLASS	16 Bar Water 10 Bar Gas
TRADEMARK	NTG
EXECUTION	Injection Moulded
STANDARD	EN 12201-3 EN 1555-3 AS / NZS 4129

SPECIFICATION	Suitable for SDR9...17 pipe 4 mm pin connectors
---------------	--

EF SPECIFICATION

WELDING VOLTAGE	40V
RESISTANCE	3,45 Ω
WELDING TIME	120 Sec.
COOLING TIME	15 Min.
WINDING TYPE	Monofilar
WELDING BARCODE	



971420320753403456120112

Tolerance on diameters and thickness according to the standards. The other dimensions are specialized. Tolerance $\pm 5\%$. NTG PLASTIK reserves all the right to change any information without giving prior notice. The production, distribution and utilization of this document without explicit authorization is prohibited.